

1. MAXIMUM PANEL THICKNESS = 6.10 [.240]
2. USE INSTRUCTION SHEET 408-1914-03

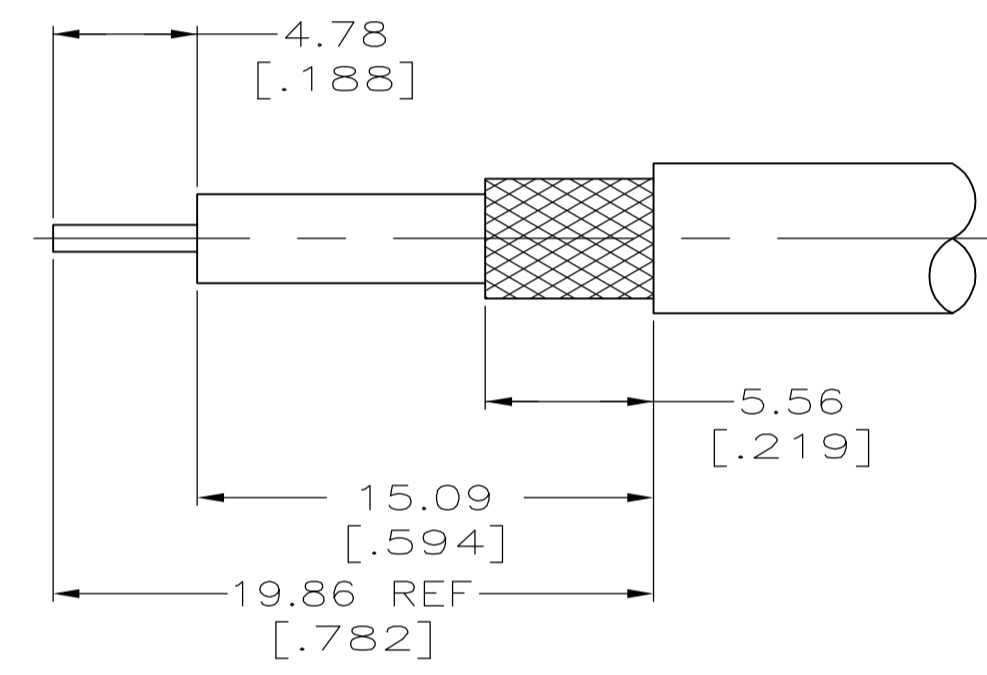

RECOMMENDED PANEL CUTOUT

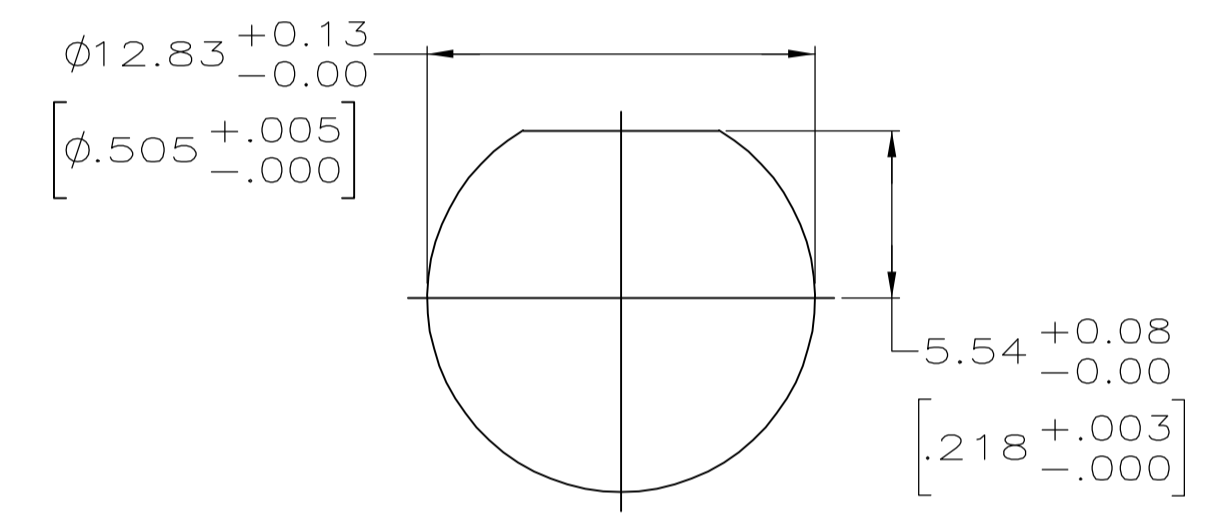

RECOMMENDED PANEL CUTOUT

34.93	[1.375]	RD-316 DOUBLE BRAIDED	-	69477-2	21427-4	1-329631-2	1-329632-2	329633	9-329049-0	1-331368-2	1-331786-6	1-5225398-5
34.93	[1.375]	RG-179/U & 187/U CABLE	.557 OZ	220009-1	21427-4	1-329631-2	1-329632-2	329633	9-328666-0	1-331368-4	1-331786-6	5225398-8
34.93	[1.375]	RG-174/U & 188/U	.582 OZ	220009-1	21427-4	1-329631-2	1-329632-2	329633	9-328666-0	1-331368-2	1-331786-6	5225398-7
38.10	[1.500]	RG-142/U,142A/U & 142B/U	-	220189-3	-	1-329631-2	1-329632-2	329633	9-225382-0	1-331369-7	1-331786-4	5225398-6
38.10	[1.500]	RG55/U,55A/U,55B/U & 223/U	.568 OZ	69478-1	-	1-329631-2	1-329632-2	329633	9-225382-0	1-331369-6	1-331786-4	5225398-3
34.93	[1.375]	RG-58/U,58A/U,58B/U & 58C/U	.582 OZ	69478-1	-	1-329631-2	1-329632-2	329633	9-50427-1	1-331369-6	1-331786-4	5225398-1
L		CABLE	WEIGHT	CRIMP TOOL	⑦ BUSHING QTY=1	⑥ JAM NUT QTY=1	⑤ LOCK WASHER QTY=1	④ GASKET QTY=1	③ FERRULE QTY=1	② CONTACT QTY=1	① JACK ASSEMBLY QTY=1	PART NUMBER

THIS DRAWING IS A CONTROLLED DOCUMENT.

DIMENSIONS: MM [INCHES]	TOLERANCES UNLESS OTHERWISE SPECIFIED: 0 PLC ± - 1 PLC ± - 2 PLC ± 0.41 [.016] 3 PLC ± - 4 PLC ± - ANGLES ± -	DWN A. FERNANDEZ-DOCK5 31JAN2005	tyco Electronics	Tyco Electronics Corporation Harrisburg, PA 17105-3608
MATERIAL	FINISH	CHK J. HAVENER 31JAN2005	NAME J. LIPPERT	RESTRICTED TO
		PRODUCT SPEC	APPLICATION SPEC	SIZE A1
		WEIGHT	SCALE 4:1	SHEET 1 OF 1
		CUSTOMER DRAWING	DRAWING NO 00779	REV 0

JACK, BULKHEAD, BNC
 5225398